

You will not be informed separately if we change any marking or indication on cables according with approval organization ' s requirement !

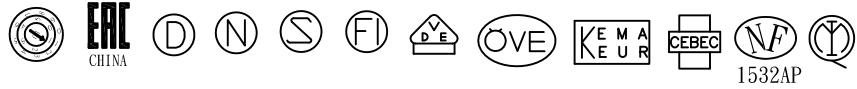

5000±80

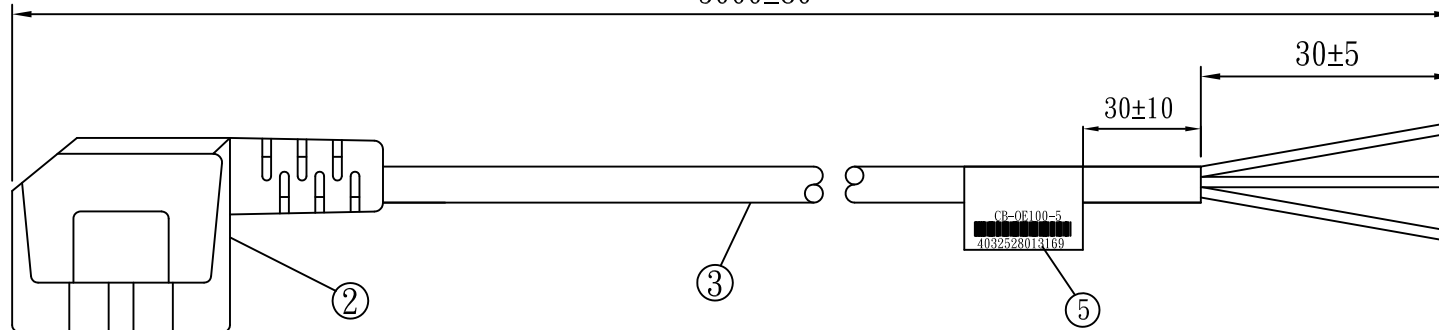

230±30

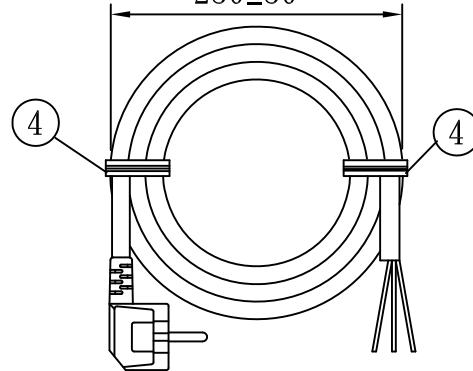

30±3mm

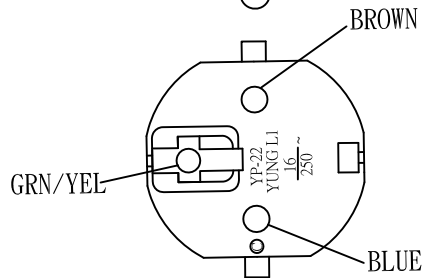
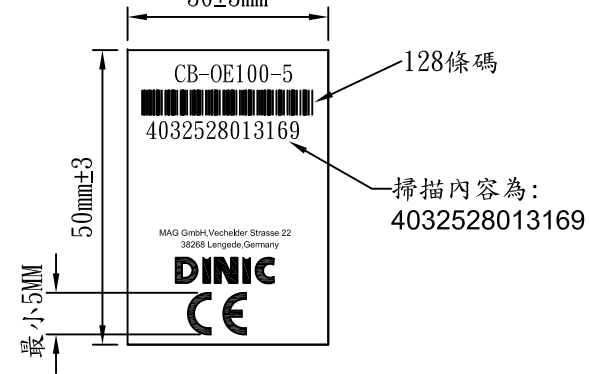

NO.	SPECIFICATION	QTY	REMARK
1	Euro plug inner model:98651	1PC	
2	YP-22 PVC PLASTIC:50P BLACK	34g/PC	
3	H05VV-F 1.0/3G BLACK	1PC	
4	MINI TIE BLACK	2PCS	
5	LABEL:50x30mm	1PC	

Tolerance >0±0.30 >1.0±0.50 >10.0±1.0 >20.0±2.0 Angle: ±1°	Approved		Date		YUNG LI CO., LTD			
	Checked		Date					
	Drawn	SUKI	Date	22.11.03	Customer	MAG		
	Cat. No.	YP-22/STRIP			P/N.	CB-OE100-5		
	Drawing No.		Rev.	B	Material	P.V.C	Unit	mm
				Scale				